

KitchenAid[®]

*No-Frost
Refrigerator-Freezer*

**Superba Series
Model KTRI18K**



USE and CARE GUIDE

Table of Contents

	Page		Page
Ownership Registration	2	Base Grille	10
Important Safety Instructions	3	Defrost Pan	10
Refrigerator-Freezer Features	4	Changing the Light Bulbs	10
Installing the		Sounds You May Hear	11
Refrigerator-Freezer	5	To Save Energy	11
Clean It	5	Food Storage Guide	12-13
Plug It In	5	Vacation and Moving Care	13
Locate Properly	5	Cleaning the	
Level Refrigerator-Freezer	5	Refrigerator-Freezer	14
Using the		If You Need Service	
Refrigerator-Freezer	6	or Assistance	15
Temperature Controls	6	KitchenAid Freestanding	
Power Saving Control	6	Refrigerator Warranty	Back Cover
Door Bins	7		
Refrigerator Shelves	7		
Meat Drawer	7		
Crispers	8		
Freezer Shelf	8		
Ice Cube Trays	8		
Optional Automatic Ice Maker ...	9		

©1994 KitchenAid

Ownership Registration

Please fill out and mail your Ownership Registration Card packed with the Literature Package. This card will enable us to contact you in the unlikely event of a product safety notification and assist us in complying with the provisions of the Consumer Product Safety Act. Return of this card is not necessary to validate your warranty.

You must provide proof of purchase or installation date for in-warranty service.

Write down the following information. You will need it if your refrigerator ever requires service.

Model Number* _____

Serial Number* _____

Date Purchased _____

Date Installed _____

Builder's or Dealer's Name _____

Address _____

Phone _____

*Model and serial numbers are located on a label on inside wall of refrigerator.

Important Safety Instructions

⚠ WARNING

To reduce the risk of fire, electrical shock, or injury when using the refrigerator, follow basic precautions including the following:

- Read all instructions before using the refrigerator.
- Child entrapment and suffocation are not problems of the past. Junked or abandoned refrigerators are still dangerous... even if they will "just sit in the garage a few days."
If you are getting rid of your old refrigerator, do it safely. Please read the enclosed safety booklet from the Association of Home Appliance Manufacturers. Help prevent accidents.
- Never allow children to operate, play with, or crawl inside the refrigerator.
- Never clean refrigerator parts with flammable fluids. The fumes can create a fire hazard or explosion.

•FOR YOUR SAFETY•

DO NOT STORE OR USE GASOLINE OR OTHER FLAMMABLE VAPORS AND LIQUIDS IN THE VICINITY OF THIS OR ANY OTHER APPLIANCE. THE FUMES CAN CREATE A FIRE HAZARD OR EXPLOSION.

It is your responsibility to be sure your refrigerator:

- is installed and leveled on a floor that will hold the weight, and in an area suitable for its size and use.
- is connected only to the right kind of outlet, with the right electrical supply and grounding. (Refer to the Electrical Requirements and Grounding Instructions Sheet.)
- is used only to do what home refrigerators are designed to do.
- is not near an oven, radiator or other heat source.
- is properly maintained.
- is out of the weather.
- is used in an area where the room temperature will not fall below 55°F (13°C).
- is not used by anyone unable to operate it properly.
- is not loaded with food before it has time to get properly cold.

SAVE THESE INSTRUCTIONS

Refrigerator-Freezer Features

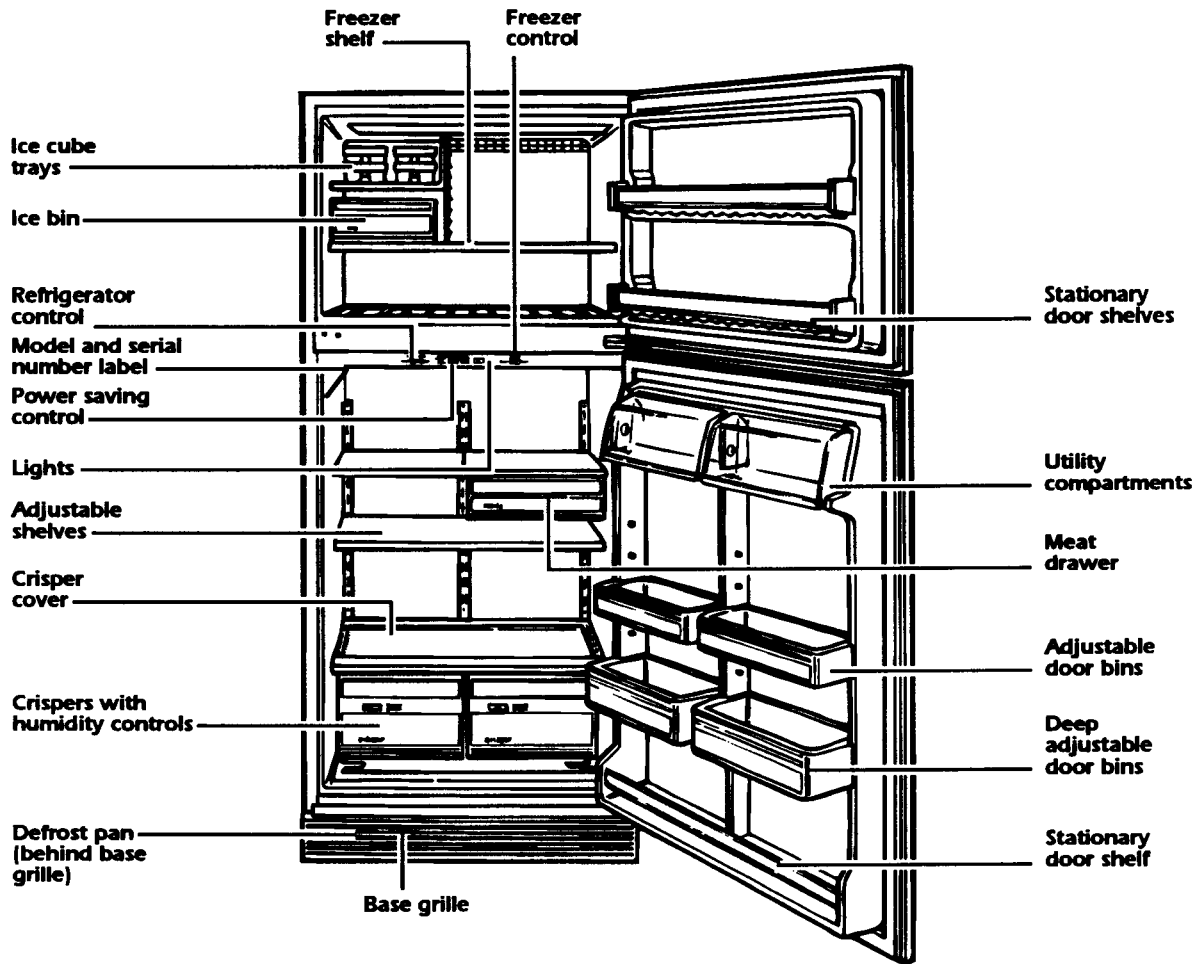

Installing the Refrigerator-Freezer

Clean It

Clean your refrigerator before using it. See cleaning instructions on page 14.

Remove the Consumer Buy Guide label and any shipping tape before using the refrigerator.

To remove any remaining glue:

1. Rub briskly with thumb to make a ball, then remove.
- OR**
2. Soak area with liquid hand dishwashing detergent before removing glue as described in step 1.

IMPORTANT: DO NOT USE sharp instruments, rubbing alcohol flammable fluids or abrasive cleaners. These can damage the finish. See "Important Safety Instructions" on page 3.

DO NOT REMOVE the Tech Sheet fastened under the refrigerator, behind the base grille.

Plug It In

3-prong grounding type wall receptacle

3-prong grounding plug

Refrigerator power cord

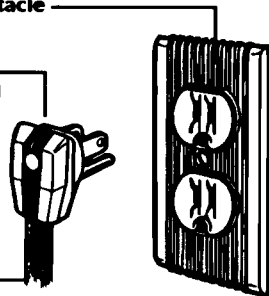

Recommended grounding method

A 115 Volt, 60 Hz., AC only, 15 or 20 Amp fused and properly grounded electrical supply is required. It is recommended that a separate circuit serving only this appliance be provided.

Do not use an extension cord. Use a receptacle which cannot be turned off with a switch or pull chain. See Electrical Requirements and Grounding Instruction Sheet in your Literature Package.

Locate Properly

1. Allow 1/2 inch (1.25 cm) on each side of the refrigerator for ease of installation.
2. If the refrigerator is to be against a wall, you might want to leave extra space on the hinge side so the door can be opened wider.
3. The refrigerator back can be flush against the wall.

Level Refrigerator-Freezer

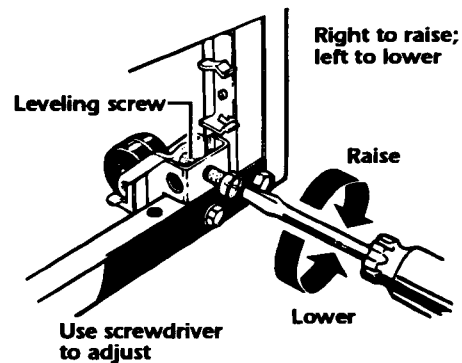

1. Remove base grille. (See page 10.)
2. To raise front, turn each screw clockwise.
3. To lower front, turn each screw counter-clockwise.
4. Check with level.

Using the Refrigerator-Freezer

Temperature Controls

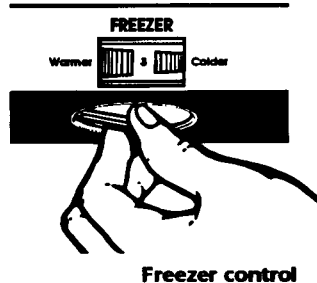
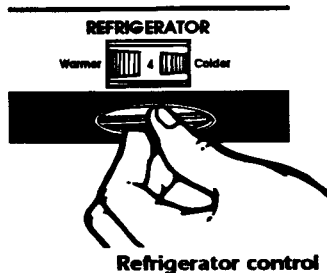

Controls for the refrigerator and freezer are in the refrigerator. When the refrigerator is first plugged in:

1. Set the Refrigerator Control to 4.
2. Set the Freezer Control to 3.

These settings are correct for normal household refrigerator usage.

Give the refrigerator time to cool down completely before adding food. (This may take several hours.) The controls are set correctly when milk or juice is as cold as you like and when ice cream is firm.

To change the temperature setting, follow the steps given below:

1. Adjust the Refrigerator Control first.
2. Wait at least 24 hours before making further adjustments. This gives the refrigerator and/or freezer time to reach set temperature.
3. Adjust the Freezer Control, if necessary.

Changing either the Refrigerator Control or Freezer Control will affect the temperature of both compartments.

Use the settings listed in the chart below as a guideline when adjusting temperature controls:

CONDITION	RECOMMENDED CONTROL SETTING ADJUSTMENTS:	
If refrigerator section is too warm.	Refrigerator	6
	Freezer	4
If freezer section is too warm.	Refrigerator	4
	Freezer	1
If refrigerator section is too cold.	Refrigerator	2
	Freezer	1
If ice isn't made fast enough.	Refrigerator	4
	Freezer	1
If both sections are too warm.	Refrigerator	6
	Freezer	3

The following reasons can cause the conditions listed above:

- Door opened often.
- Large amount of food added.
- Room temperature too warm.
- Room temperature too cold. (Refrigerator doesn't cycle often enough.)
- Controls not set correctly for your conditions.
- Heavy ice usage.

Power Saving Control

POWER SAVING CONTROL



The **POWER SAVING CONTROL** on the Control Console operates electric heaters around the door openings. These heaters help keep moisture from forming on the outside of the refrigerator.

1. Use the **Consumes Less Energy** setting (indicator light off) when humidity is low.
2. Use the **Reduces Exterior Moisture** setting (indicator light on) only if moisture forms on the outside of the refrigerator.

Door Bins

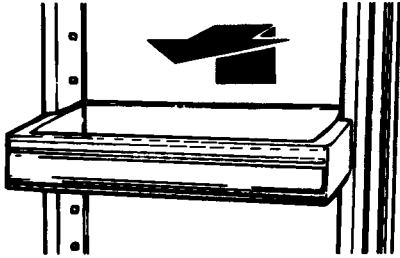

To remove:

1. Lift up bin.
2. Pull bin straight out.

To replace:

1. Slide bin in above desired button.
2. Push down until it stops.

Meat Drawer

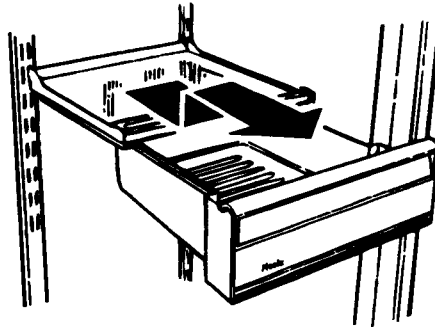

To remove meat drawer:

1. Slide meat drawer out to the stop.
2. Lift the front.
3. Slide the drawer the rest of the way out.
4. Replace in reverse order.

To remove cover:

1. Tilt front of cover up.
2. Lift up at back.
3. Pull straight out.
4. Replace in reverse order.

IMPORTANT: Glass shelves are heavy. Handle with care.

Refrigerator Shelves

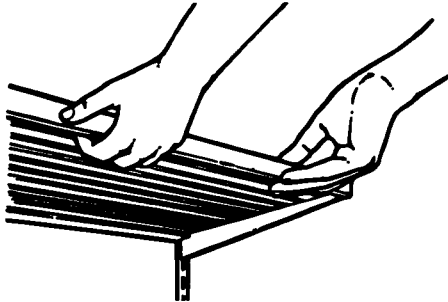

Adjust shelves to match the way you use your refrigerator.

To remove:

1. Tilt up at front.
2. Lift up at back.
3. Pull shelf straight out.

IMPORTANT: Glass shelves are heavy. Handle with care.

To replace:

1. Guide the rear hooks into the slots in the shelf supports.
2. Tilt up front of shelf until hooks drop into slots. Lower front of shelf to level position. Check the stability of the shelf to be sure hooks have been properly inserted.

Crispers

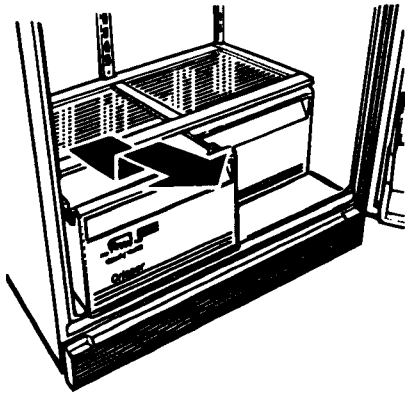

To remove crispers:

1. Slide crispers straight out to the stop, lift front, then slide the rest of the way out.
2. Replace in reverse order.

To remove cover:

1. Push up glass insert from bottom, then slide out with both hands.
2. Lift front of cover frame.
3. Lift out cover frame by pulling up and out.
4. Remove metal cover support.

To replace cover:

1. Replace metal cover support on wall supports in front section of cabinet.
2. Fit back corners into notched supports on walls of refrigerator, then lower into place.
3. Slide back of glass insert into place, then lower front.

To adjust crisper humidity control:

You can control the amount of humidity in the moisture-sealed crisper.

1. The control can be adjusted to any setting between LOW and HIGH.
2. LOW (open) lets moist air out of crisper for best storage of fruits and vegetables with skins.
3. HIGH (closed) keeps moist air in the crisper for best storage of fresh leafy vegetables.

Freezer Shelf

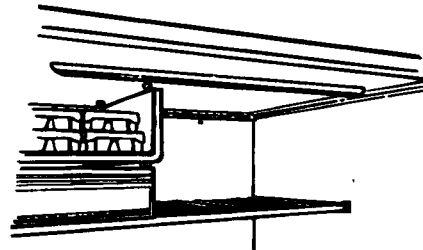

To remove:

1. Remove ice bin.
2. Lift front slightly.
3. Lift back off supports.
4. Pull shelf straight out.

To replace:

Replace in reverse order.

Ice Cube Trays

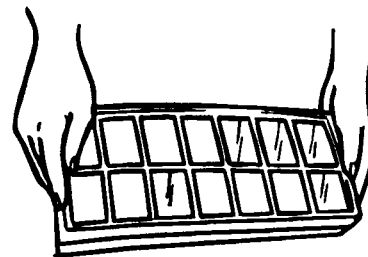

If cubes are not used, they may shrink. The moving cold air starts a slow evaporation. The longer cubes are stored, the smaller they get.

To remove ice:

1. Hold tray at both ends.
2. Twist slightly.

Optional Automatic Ice Maker

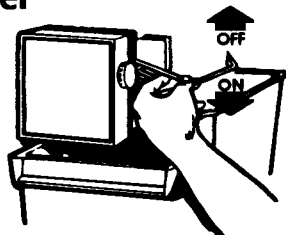

If you plan to add the ice maker (Part No. KIMS9), there are a few things you will want to know:

- The ON/OFF lever is a wire signal arm.
DOWN to make ice automatically.
UP to shut off the ice maker.
IMPORTANT: Do not turn ice maker on until it is connected to the water supply. **Instructions for ice maker water supply hook-up are attached to the back of the refrigerator cabinet.**
- The dial or lever on the side of the ice maker changes the size of the cubes.
- Shake the bin occasionally to keep cubes separated and to obtain increased storage capacity.
- It is normal for ice crescents to be attached by a corner. They break apart easily.
- You will hear water running when ice maker is working. You'll hear ice fall into the bin. Don't let these sounds bother you.
- The ice maker will not operate until the freezer is cold enough to make ice. This can take overnight.
- Because of new plumbing connections, the first ice may be discolored or off-flavored. Discard the first few batches of ice.
- If ice is not being made fast enough, and more ice is needed, move the Refrigerator Control toward a higher number. Wait a day and, if necessary, move the Freezer Control toward 3.

- If you remove the ice bin, raise the signal arm to shut off the ice maker. When you return the bin, push it all the way in and lower the arm to the ON position.
- If cubes are stored too long, they may develop an off-flavor ... like stale water. Throw them away. Ice maker will make new ice. Cubes in the ice bin can also become smaller by evaporation.
- Good water quality is important for good ice quality. Try to avoid connecting the ice maker to a softened water supply. Water softener chemicals, such as salt from a malfunctioning softener, can damage the ice maker mold and lead to poor ice quality. If a softened water supply cannot be avoided, it is important that the water softener be well maintained and operating properly.

Base Grille

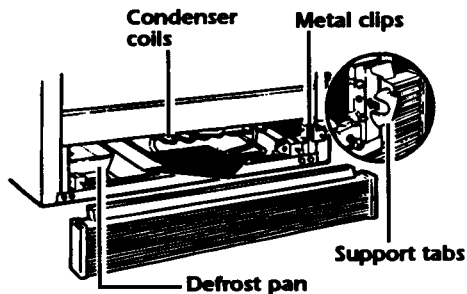

To remove base grille:

1. Open the refrigerator door.
2. Pull grille out.
3. **Do not remove Tech Sheet** fastened behind the grille.

To replace:

1. Line up grille support tabs with metal clips.
2. Push firmly to snap into place.
3. Close the refrigerator door.

See cleaning instructions for defrost pan and condenser coils on page 14.

Defrost Pan

⚠ WARNING

Personal Injury Hazard
Refrigeration system tubes are located above the defrost pan and can become hot. Remove and install defrost pan carefully. Failure to do so could cause personal injury.

To remove defrost pan:

1. Remove base grille. See above.
2. Lift defrost pan over wire brace. Remove tape, if any.
3. Clean as described on page 14.

To replace:

1. Replace with notched corner to the rear.
2. Push pan in all the way. Make sure defrost drain tube is directed into pan.
3. Replace base grille. See above.

Changing the Light Bulbs

⚠ WARNING

Electrical Shock Hazard
Before removing a light bulb, either unplug the refrigerator or disconnect the electricity leading to the refrigerator at the main power supply. Shock and injury can occur if electricity remains connected.

To change light bulb in refrigerator:

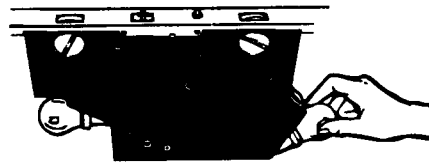

1. Disconnect refrigerator from power supply.
2. Reach behind the Control Console to find bulbs.
3. Remove bulb.
4. Replace with a 40-watt appliance bulb.
5. Reconnect power supply.

Sounds You May Hear

Your new refrigerator may make different sounds than your previous one. Hard surfaces such as the ceiling, walls, and cabinets around the refrigerator can make sounds seem louder.

The following chart describes the kinds of sounds that might be new to you and what causes them.

SOUNDS/OBSERVATIONS	CAUSES
Hum or hiss	The refrigerator's fan motor and moving air.
Clicking or snapping sounds	The thermostat makes a definite click when the refrigerator stops running. It also makes a sound when the refrigerator starts. The defrost timer will click when the defrost cycle starts and stops.
Running sounds	The high-efficiency compressor and motor will run longer than older designs.
Trickling water/ water sounds	During the defrost cycle, the refrigerator will not be running. The trickling water is the frost accumulation on the freezer coil melting and running into the defrost pan. When the refrigerator stops running, you may hear gurgling in the tubing for a few minutes.

To Save Energy

- Open the doors as few times as possible. Keep food organized so you do not have to search for what you want. Get everything you need out at one time. Close the door as soon as food is removed.
- Set the refrigerator and freezer temperatures to suit your needs; ice cream should be firm and beverages should be as cold as you like them. Avoid setting the refrigerator and freezer temperatures colder than is necessary.
- Make sure your refrigerator is not next to a heat source such as a range, water heater, furnace, radiator, or in direct sunlight.
- Keep the **POWER SAVING CONTROL** in the **Consumes Less Energy** position (indicator light off) unless moisture forms on refrigerator exterior.
- Check door gasket for tight seal. Level the cabinet to ensure a good seal.
- Clean the condenser coils regularly.

Food Storage Guide

Fresh Food

Vegetables

- **Leafy**
Remove store wrapping. Tear off bruised and discolored areas. Wash in cool water, drain. Place in plastic bag or container and store in crisper.
- **With skins**
Place in plastic bags or containers and store in crisper.

Fruit

- **Berries**
Sort to remove injured berries. Do not wash berries until they are to be served. Store in original container in crisper.
- **Other**
Sort to remove injured fruit before storing. Wash fruit, let dry, place in perforated plastic bag or loosely covered plastic container and store in crisper.

Eggs

Store in original carton. For best storage, place on interior shelf.

Dairy Products

- **Milk**
Store in original container on refrigerator shelf.
- **Butter or margarine**
Store in the utility compartment or on refrigerator shelf until opened. When opened, store in covered dish or on butter dish in the utility compartment.
- **Cheese**
Store in original packaging until opened. When opened, tightly rewrap in plastic wrap or aluminum foil and store in utility compartment or on refrigerator shelf.

Leftovers

Cover with plastic wrap or aluminum foil, or place in plastic containers with tight fitting lids.

Condiments

Store small jars and bottles in door bins.

Beverages

Wipe off bottles and cans. Store in door bins or on refrigerator shelves.

Meat

- **Cured or smoked meat and cold cuts**
Store in original packaging until opened. When opened, tightly rewrap using plastic wrap or aluminum foil.
- **Fresh, prepackaged meat & poultry**
Store in original packaging.
- **Fresh meat, not prepackaged**
Remove market wrapping paper. Rewrap in aluminum foil.
- **Fresh poultry, not prepackaged**
Remove market wrapping paper. Rewrap in plastic wrap.
- **Cooked meat & poultry**
Wrap or cover with plastic wrap or aluminum foil. Store immediately.
- **Fresh fish & shellfish**
Store in plastic bag or tightly covered container.

REFRIGERATOR STORAGE CHART FOR FRESH AND CURED MEAT*

Type	Approximate Time (Days)
Chicken	1 to 2
Ground beef	1 to 2
Variety meat	1 to 2
Steaks and roasts	3 to 5
Cold cuts	3 to 5
Bacon	5 to 7
Cured meat	7 to 10

* If storing meat longer than the times given, freezing is recommended.

IMPORTANT: Use fresh fish and shellfish the same day as purchased.

Frozen Food

Prepackaged frozen food

Store in original packaging on freezer door shelf or on freezer shelf.

Meat/poultry

Trim off excess fat and remove bones when necessary. Meat/poultry should not be salted. Wrap tightly in heavy-duty aluminum foil, plastic-coated wrapper, or non-permeable plastic wraps (made from a saran film). Press out as much air as possible. Label and date the meat/poultry. Do not refreeze thawed meat.

Ice Cream

Store in original packaging. When opened, place piece of aluminum foil or waxed paper against ice cream surface to prevent the formation of ice crystals.

Frozen juices

Store in original container on freezer door shelf or on freezer shelf.

STORAGE CHART FOR FROZEN FOOD*

Type	Approximate Time (Months)
Bread	2
Cooked dishes	2 to 3
Fish and seafood	
• fresh	6
• commercially frozen	1 to 3
Fruit	6
Ice cream	1
Concentrated juice	4 to 6
Meat	
• bacon	less than 1
• pork roast, chops	3 to 4
• sausage	1 to 2
• beef, veal, lamb roasts	6
• ground meat	1 to 2
• poultry	3 to 4
Vegetables	6

*Storage times given in this chart are only a guide. For best use of freezer space, keep frozen food for short times. Use, then replace as needed.

Courtesy of National Livestock & Meat Board and U.S.D.A.

Vacation and Moving Care

Long Vacations

Remove all food if you are going for a month or more.

Unplug the refrigerator. Clean it, rinse well and dry. Tape rubber or wood blocks to the top of both doors to prop them open far enough for air to get in. This keeps odor and mold from building up.

WARNING

Personal Injury Hazard

Do not allow children to climb on, play near or climb inside the refrigerator when the doors are blocked open. They may become injured or trapped.

To restart the refrigerator, see "Using the Refrigerator-Freezer" on page 6.

Short Vacations

If you will be away for less than four weeks, there is no need to shut off the refrigerator. Use up perishables and freeze other items.

Moving

Remove all food and pack it in dry ice. Unplug the refrigerator. Clean it thoroughly, rinse well and dry. Take out all removable parts. Wrap all parts well and tape them together so they don't shift and rattle. Screw in the leveling rollers. Tape the doors shut, and tape the electric cord to the cabinet.

When you get to your new home, put everything back and refer to page 5.

Cleaning the Refrigerator-Freezer

The refrigerator and freezer sections defrost automatically. However, clean both once a month to prevent odors from building up. Wipe up spills immediately.

To clean, turn the Refrigerator Control to off, unplug it, take out all removable parts, and clean the refrigerator according to the directions given below.

Cleaning Chart

PART	WHAT TO USE	HOW TO CLEAN
Removable parts (shelves, crispers, etc.)	<ul style="list-style-type: none"> • Sponge or cloth • Mild detergent and warm water 	<ul style="list-style-type: none"> • Wash, rinse and dry well.
Exterior surfaces	<ul style="list-style-type: none"> • Sponge, soft cloth or paper towel • Mild detergent • Appliance wax or good auto paste wax 	<ul style="list-style-type: none"> • Wash. • Do not use abrasive or harsh cleansers. • Rinse and dry well. • Wax painted metal surfaces at least twice a year. Apply wax with a clean, soft cloth. Waxing painted metal surfaces provides rust protection. • Do not use wax on plastic parts.
Interior walls	<ul style="list-style-type: none"> • Sponge, soft cloth or paper towel • Mild detergent • Warm water 	<ul style="list-style-type: none"> • Wash, rinse and dry well.
Door liners and gaskets	<ul style="list-style-type: none"> • Sponge, soft cloth or paper towel • Mild detergent • Warm water 	<ul style="list-style-type: none"> • Wash, rinse and dry well. • Do not use cleaning waxes, concentrated detergents, bleaches, or cleaners containing petroleum or alcohol on plastic parts.
Base grille	<ul style="list-style-type: none"> • Vacuum cleaner with brush attachment 	<ul style="list-style-type: none"> • Vacuum grille.
Defrost pan	<ul style="list-style-type: none"> • Sponge or cloth • Mild detergent • Warm water 	<ul style="list-style-type: none"> • See page 10 for removal and replacement instructions. • Wash, rinse and dry well.
Condenser coils	<ul style="list-style-type: none"> • Vacuum cleaner with extended narrow attachment 	<ul style="list-style-type: none"> • Should be cleaned periodically. • Remove base grille. (See page 10.) • Vacuum coils. • Replace base grille.

If You Need Service or Assistance

Follow These Steps

1. If the refrigerator fails to operate, review the following list before calling your dealer. You could save the cost of a service call.

If the refrigerator will not operate:

- Is the electric cord plugged in?
- Is a fuse blown or circuit breaker tripped?
- Is the Refrigerator Control in the OFF position?

If the refrigerator makes unfamiliar sounds:

- New features on your refrigerator make new sounds. You may be hearing air flowing from fans, timer clicks for the defrosting cycle, or defrost water draining into the defrost pan. See page 11.

If there is water in the defrost pan:

- This is normal in hot, muggy weather. The pan can even be half full. Make sure the refrigerator is level so the pan does not overflow.

If the lights are not working:

- Is a fuse blown or circuit breaker tripped?
- Is a light bulb burned out? See instructions for changing light bulbs on page 10.

If the motor seems to run too long:

- The motor naturally runs longer on hot days or if the room is warm, as well as when a large amount of food has been put into the refrigerator or the doors have been opened a lot.

2. If the problem is not due to one of the above items:*

- Call KitchenAid Consumer Assistance Center, TOLL-FREE:
1-800-422-1230

and talk with one of our trained consultants. The consultant can instruct you in how to obtain

satisfactory operation from your appliance or, if service is necessary, recommend a qualified service company in your area.

- If you prefer, write to:

Consumer Assistance Center
KitchenAid
2000 M-63
Benton Harbor, MI 49022
Please include a daytime phone number in your correspondence.

3. If you need service:*

- Call your dealer or the repair service he recommends.
- All service should be handled locally by the dealer from whom you purchased the unit or an authorized KitchenAid servicer.
- If you are unable to obtain the name of a local authorized KitchenAid servicer, call our service assistance number (see Step 2).

4. If you are not satisfied with the action taken:*

- Contact the Major Appliance Consumer Action Panel (MACAP). MACAP is a group of independent consumer experts that voices consumer views at the highest levels of the major appliance industry.
- Contact MACAP only when the dealer, authorized servicer, or KitchenAid have failed to resolve your problem.

Major Appliance Consumer
Action Panel
20 North Wacker Drive
Chicago, IL 60606

- MACAP will in turn inform us of your action.

*When requesting assistance, please provide: Model Number, Serial Number, Date of Purchase and a complete description of the problem. This information is needed in order to better respond to your request.

KitchenAid®

Freestanding Refrigerator Warranty

LENGTH OF WARRANTY:	KITCHENAID WILL PAY FOR:	KITCHENAID WILL NOT PAY FOR:
ONE YEAR FULL WARRANTY FROM DATE OF PURCHASE.	Replacement parts and repair labor costs to correct defects in materials or workmanship. Service must be provided by an authorized KitchenAid servicing outlet.	A. Service calls to: 1. Correct the installation of the refrigerator. 2. Instruct you how to use the refrigerator. 3. Replace house fuses or correct house wiring. 4. Correct house plumbing.
SECOND THROUGH FIFTH YEAR FULL WARRANTY FROM DATE OF PURCHASE.	Replacement parts and repair labor costs to correct defects in materials or workmanship in the sealed refrigeration system. These parts are: 1. Compressor 2. Evaporator 3. Condenser 4. Drier 5. Connecting Tubing Service must be provided by an authorized KitchenAid servicing outlet.	B. Repairs when refrigerator is used in other than normal home use. C. Damage resulting from accident, alteration, misuse, abuse, improper installation or installation not in accordance with local electrical or plumbing codes.
SIXTH THROUGH TENTH YEAR LIMITED WARRANTY FROM DATE OF PURCHASE.	Replacement parts to correct defects in materials or workmanship in the sealed refrigeration system. These parts are: 1. Compressor 2. Evaporator 3. Condenser 4. Drier 5. Connecting Tubing	D. Any food loss due to product failure. E. Any labor costs during the limited warranty. F. Replacement parts or repair labor costs for units operated outside the United States.
SECOND THROUGH FIFTH YEAR FULL WARRANTY FROM DATE OF PURCHASE.	Replacement or repair of the refrigerator/freezer cavity liner if the part cracks due to defective material or workmanship. Service must be provided by an authorized KitchenAid servicing outlet.	G. Pick up and delivery. This product is designed to be repaired in the home. H. Repairs to parts or systems caused by unauthorized modifications made to the appliance.

KITCHENAID DOES NOT ASSUME ANY RESPONSIBILITY FOR INCIDENTAL OR CONSEQUENTIAL DAMAGES. Some states do not allow the exclusion or limitation of incidental or consequential damages, so this exclusion or limitation may not apply to you.

This warranty gives you specific legal rights and you may also have other rights which vary from state to state.

If you need service, first see the "Service and Assistance" section of this book. After checking "Service and Assistance," additional help can be found by calling our service assistance telephone number, **1-800-422-1230**, from anywhere in the U.S.A.

KitchenAid
St. Joseph, Michigan, U.S.A. 49085



Printed on recycled paper—
10% post consumer waste
50% recovered materials

Part No. 1126160 Rev. A
© 1994 KitchenAid

® Registered Trademark of KitchenAid

Printed in U.S.A.